

®ICP Accelerometer Model 104 Premium, Side connector

Main Characteristics

- -55°C to 120 °C (-67°F to 250°F)
- ®ICP transmission mode
- Annular shear mode
- Dual case isolation with Faraday shield
- Low, medium and high frequency version
- High temperature version
- IP67 with associated cable (B=2 only)
- Complies with API 670 requirements (A=6 only)

Competitive advantage

- Annular shear mode is less susceptible to transverse vibrations and better immune to electronic saturation at high frequency
- Exceptional bias voltage stability at elevated temperatures.
- Low cost IP67 overmolded M12 cable assembly
- M12 overmolded cable assembly is available through local electronic distributor
- M12 offers compatibility with sensors used in automation

Description

The hermetic sealed industrial piezoelectric accelerometer model 104 is design to monitor the vibration in harsh industrial environment. It uses the industry standard ®ICP 2-wire voltage transmission technique with a 4 mA minimum constant current supply. Signal ground is isolated from the mounting surface and outer case to prevent ground loops. Faraday shielding will limit sensitivity to ESD to a minimum. Annular shear mode design will prevent from thermal transient and from spurious signal from high transverse vibrations. Low noise electronic and a temperature compensated design will give you accurate result over the complete temperature range. Large choice of frequency range will help to fit almost every customer requirements. Low frequency accelerometers (A=9) incorporate a low-pass filter within the conditioning electronics. This filter attenuate the sensor mechanical resonance and the associated distortion and overload.

Typical applications

Vibrations measurement in the rugged environments of industrial machinery monitoring. High frequency version will monitor the vibration on roller bearing, pumps cavitation, Medium frequency version will monitor overall vibration on pumps, motors, fans, ... Low frequency model is used in the petrochemical, machine tool, and paper industries for monitoring of slow speed agitators, cooling towers,

Ordering information Model 104.01 (120°C version)

To order, specify model number, options and suffix :

104.01- A - B - Options - Accessories

A : Sensitivity

- 3 : 10 mV/g (high frequency)
 - 6 : *100 mV/g (medium frequency, general purpose)
 - 9 : 500 mV/g (low frequency)
- Available suffix : N, negative polarity

B : Connector / Integral cable

- 1 : *MIL-C-5015, glass seal
- 2 : *M12 glass seal

Options :

Temperature output

- T0 : 10 mV/°C. (+2° to +120°C)
- Not available with Mil-C-5015 connector

Special Agency Approval

none

Accessories



Model 104.01-A-2 with overmolded connector

M8 : M8x1.25 Hex Bolt, captive

Special Engraving :

Add ZXX at the end of the part number.

XX is a number supplied by VibraSens

Ordering example :

104.01-6-2M8 Accelerometer, piezoelectric, 100mV/g, M12 glass seal connector

*Most Popular model :

104.01-6-1 and 104.01-6-2

Specifications

Dynamic

Sensitivity

A=3.....	10 mV/g ±5%
A=6.....	100 mV/g ±5%
A=9.....	500 mV/g ±5%
Frequency response.....	fig. 14a, 14b
A=3.....	±10 % : 1 to 9000 Hz
.....	±3 dB : 0.5 to 13000 Hz
A=6.....	±10 % : 1 to 6000 Hz
.....	±3 dB : 0.5 to 10000 Hz
A=9.....	±10 % : 0.4 to 1600 Hz
.....	±3 dB : 0.2 to 3700 Hz

Mounted Resonant frequency

A=3.....	32 kHz Nom
A=6.....	22 kHz Nom
A=9.....	16 kHz Nom

Dynamic range

A=3.....	500 g pk
A=6.....	80 g pk
A=9.....	10 g pk

Transverse response sensitivity (20Hz, 5g) <5% max

Temperature response (See fig13)

Polarity..... Suffix dependant

Linearity..... ±1% Max

Warm up time

A=3, 6.....	< 1Sec
A=9.....	< 10 Sec

Option T0

Output (between - and Temp).....	Vout=10mV/°C * T(°C)t
Range.....	+2° to 120°C

Electrical

Electrical Grounding..... Isolated from machine ground

..... Internal shielding

Isolation (Case to shield) -55°C to +120°C 100 MΩ Min

Capacitance to ground..... 70 pF Nom

Output impedance..... 50 ΩNom

DC output bias, 4mA supply..... 12 VDC (See Fig 12)

Residual noise (24°C) : A=3

1 Hz to 25 kHz.....	300 ug rms
1 Hz.....	30 ug

Residual noise (24°C) : A=6

1 Hz to 25 kHz.....	300 ug rms
1 Hz.....	30 ug

Residual noise (24°C) : A=9

1 Hz to 25 kHz.....	25 ug rms
1 Hz.....	2.4 ug

Power requirements Constant current : +2 to +10mA DC

..... Voltage : +22 to +28 VDC

Protection : Overvoltage Yes

Protection : Reverse polarity..... Yes

Environmental

Temperature :

Operating continuous : 104.01

A=3, 6.....	-55 to 120 °C (-65 to 250 °F)
A=9.....	-55 to 90 °C (-65 to 212 °F)

Humidity / Enclosure

B=1, 2.....	Not affected, hermetically sealed, 1E-8storr.I/s
B=3.....	IP67, epoxy sealed

Acceleration limit : Shock 5 000g peak

Acceleration limit : Continuous vibration..... 500g peak

Base strain sensitivity 0.0002 ug pk/u strain

Temp. transient sens. (3Hz, LLF, 20dB/dec) 5 mg/°C

Acoustic sensitivity (164 dBSP) 0.5 mg

Electromagnetic sens. (50Hz, 0.03 T)..... 0.2 g

Mean time between failure (MTBF)..... 10 Years Nom

ESD Protection..... > 40 V

Safety EN 61010-1 and IEC 1010-1

EMC emission..... EN 50081-1, EN 50081-2

EMC immunity (1)..... EN 50082-1, EN 50082-2

Physical

Dimensions

B=1.....	See Fig. 1a
B=2.....	See Fig. 1b

Design Ceramic, preloaded annular shear mode

Weight

A=3.....	150 gr Nom (5.2 Oz)
A=6.....	155 gr Nom (5.6 Oz)
A=9.....	165 gr Nom (6.0 Oz)

Connector 104.01

B=1.....	MIL-C-5015 glass seal, Type MS3143 10SL-4P
B=2.....	M12 glass seal, IEC 60947-5-2
B=3.....	M12 epoxy seal, IEC 60947-5-2
Material.....	AISI 316L, DIN 1.4404 (Stainless steel)
Mounting torque (M8 suffix).....	2.4 N.m (21 in-lbs)

Accessories, supplied

Calibration supplied.....	Sensitivity (5g, 160 Hz)
.....	No frequency response

Accessories, not supplied

Cable assembly

MIL connector (B=1), Polyurethane cable.....	10.01-B01-A01-01-Length
MIL connector (B=1), FEP Teflon cable.....	10.01-B01-A01-02-Length
M12 connector B=2, 3 Polyurethane cable.....	10.01-E01-A01-31-Length

PU and FEP Armored cables are also available. See Model 10.01.

Mounting Bolt

M8.....	194.01-08-1
---------	-------------

Standard Wiring color

With Mil-C-5015 cable assembly: + = Red // - = White

With M12 cable harness: : + = Black // - = Blue // Temperature=White

Repair

Consult factory for replacement of connector in case of broken or bended pins. Repair of electronic is not possible

(1) Guaranteed if using accessories listed in this datasheet only

Drawings

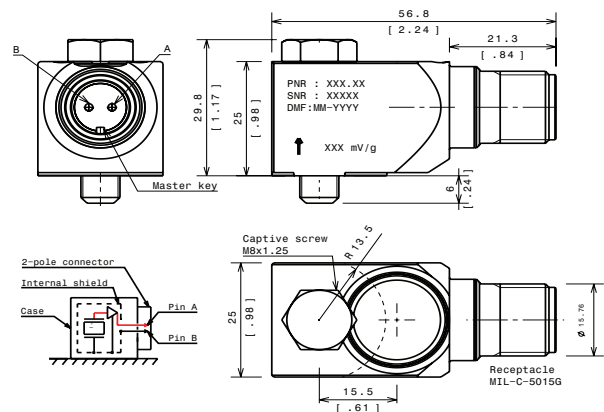

Model Number	Pin A	Pin B
Standard, no option	(+)	(-)
T0 Option (10mV/°C)	N/A	N/A

(N/A) : Not available

Fig 1a : Outline drawing & Electrical layout for B=1 (MIL-C-5015)

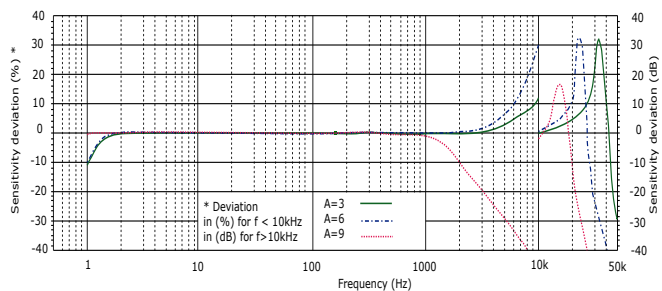
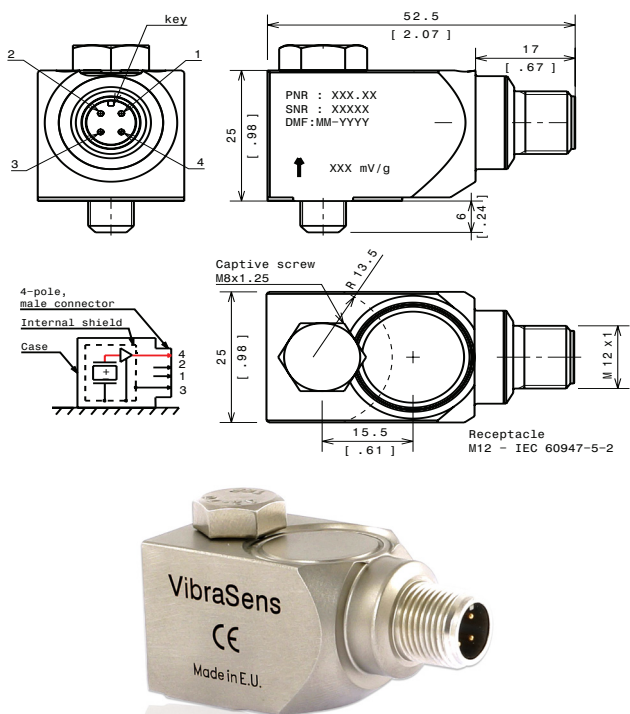

14a : Frequency response, amplitude

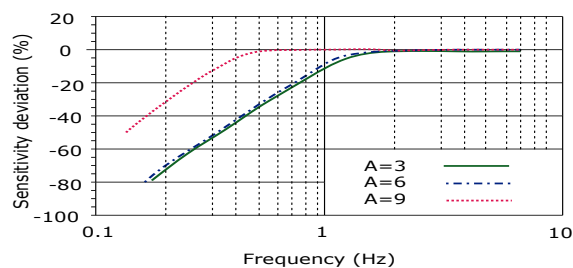

Fig 14b :Low Frequency response, amplitude

Model Number	Pin 1	Pin 2	Pin 3	Pin 4
Standard, no option	NC	NC	(-)	(+)
T0 Option (10mV/°C)	NC	(Temp)	(-)	(+)

(NC) : Not connected / (Temp) : Temperature

Fig 1b : Outline drawing & Electrical layout for M12 Connector (B=2)

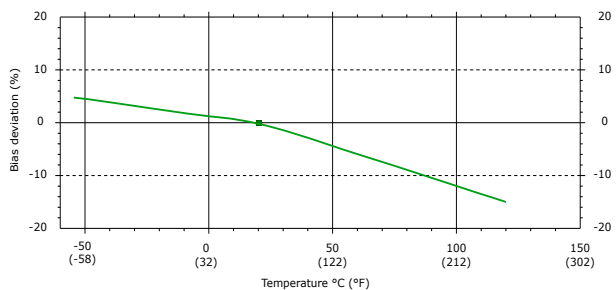

Fig 12 : DC (Bias) deviation versus temperature

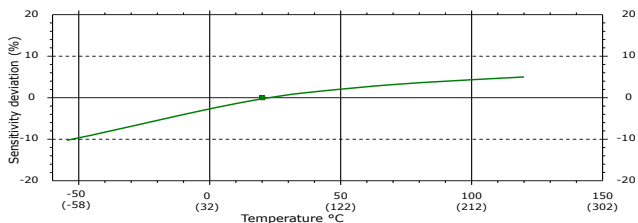

Fig 13 : Sensitivity deviation versus temperature