

## Flat magnet, Model 212

### Main Characteristics

- portable route measurements
- for top connector vibration sensors with M6 and 1/4" 28 UNF thread
- for flat surfaces only (to be used whenever possible with our magnet targets)
- stainless steel

### Description

The use of magnet bases is convenient and quick for many applications (route measurements). They produce an intimate and stiff contact between DC and few kilohertz. The high frequency response (above few kHz) is significantly distorted. Obviously the machine surface should be magnetically attractive and free of paint chips and scale. Painted surface should use our stainless steel magnet target model 208 that greatly improves the high frequency response. We also recommend the use of coupling fluids, such as oil.

Customer should pay attention to magnet attaching on the machine. The shock could overload the vibration sensor and destroy the electronic.



**Model 212.01-06-25**

### Ordering information

To order, specify part number, options and suffix :

#### 212.01- AA - BB

##### AA : Sensor thread

06 ..... M6x1  
16 ..... 1/4" 28 UNF

##### BB : Diameter

25 ..... 25 mm

##### Stocked models :

212.01-06-25 / 212.01-16-25

##### Ordering example

212.01-06-25 ..... Flat magnet, M6

##### Specifications

Dynamic  
Frequency response ..... 10% : DC to 2.5 kHz  
..... see fig 4a

Environmental  
Temperature ..... -55°C to 160 °C (-67°F to 320°F)

Physical  
Dimensions ..... See outline drawing Fig 1a  
Weight ..... ~ 63 gr (~ 2.22 Oz)  
Material ..... Stainless steel  
Magnet ..... high temperature rare earth magnet  
Pull force ..... 23 kg (50 Lbs)

Accessories  
Magnet targets ..... model 208

##### Competitors cross reference list

Wilcoxon B3 / CTC online MH103-1B - MH136-1A / PCB 080A121 (080A120) / AMPO  
EMID 22 (very low pull force)

**Outline drawing**

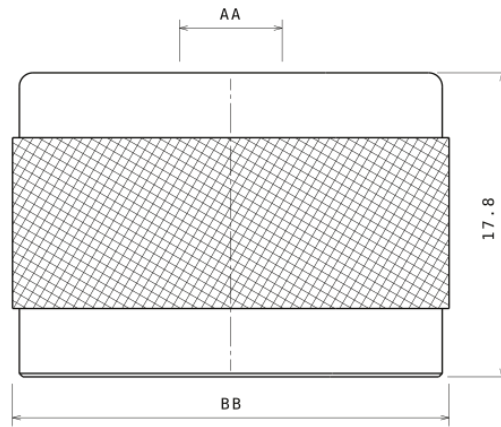

Fig 1a

**Mounting drawing**

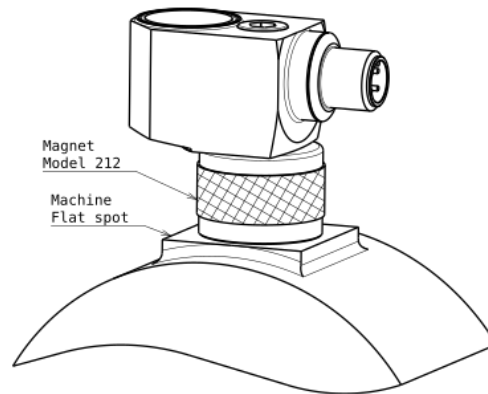

Fig 2a

**Typical frequency response**

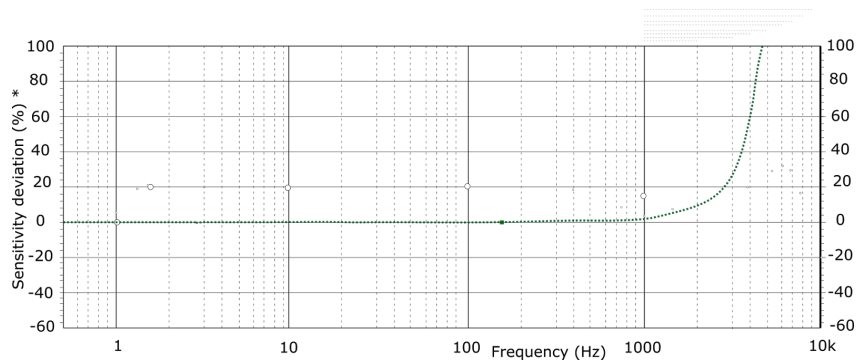

Fig 4a